

Questions are for both separate science and combined science students
unless indicated in the question

1 Photograph C shows a student using an old camera that uses film.

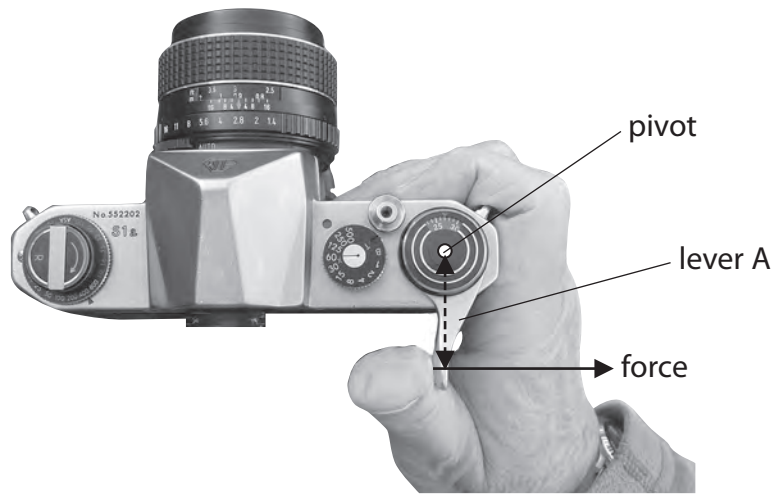

Photograph C

(a) The film is pulled through the camera using lever A.

The student pushes on lever A with a force of 7.0 N.

The force is applied 0.04 m from the pivot.

(i) State the equation linking moment, force and distance. **(separate only)**

(1)

(ii) Calculate the moment of the force that turns lever A and give the unit. **(separate only)**

(3)

Moment = unit

(b) When all the film has been used, it is pulled back through the camera using lever R.

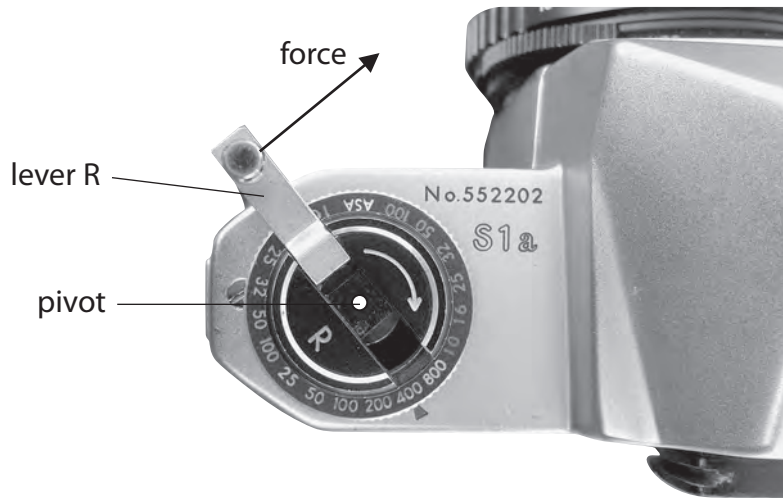

Photograph D

The force acting on lever R is only 0.02 m from its pivot.

Explain why the minimum force needed to turn lever R is likely to be more than 7 N. **(separate only)**

(2)

.....

.....

.....

.....

.....

(Total for Question 1 = 6 marks)

2 (a) Parachutes are used to slow down a spacecraft as it falls through the atmosphere.

Photograph **G** shows an Apollo spacecraft with three parachutes attached.



Photograph **G**

This spacecraft falls at a constant velocity.

(i) State the name of this constant velocity.

(1)

(ii) Explain why this velocity stays at a constant value.

(3)

- (iii) Photograph **H** shows an identical Apollo spacecraft. Only two of its parachutes are working.

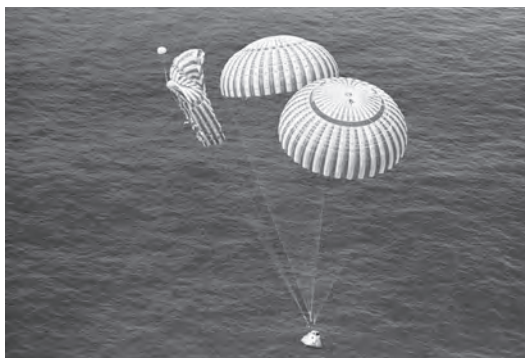

Photograph **H**

Explain how the constant velocity reached by this spacecraft compares with the constant velocity of the spacecraft shown in photograph **G**.

(2)

.....

.....

.....

.....

.....

- (b) Photograph **I** shows a Space Shuttle using a parachute when it lands on a runway.



Photograph **I**

Explain what would happen to the stopping distance of the Shuttle if this parachute did not open.

(2)

.....

.....

.....

.....

3 The diagram shows an air track that can be used to investigate motion.

Air comes out through a series of small holes in the air track.

A small glider floats on a cushion of air.

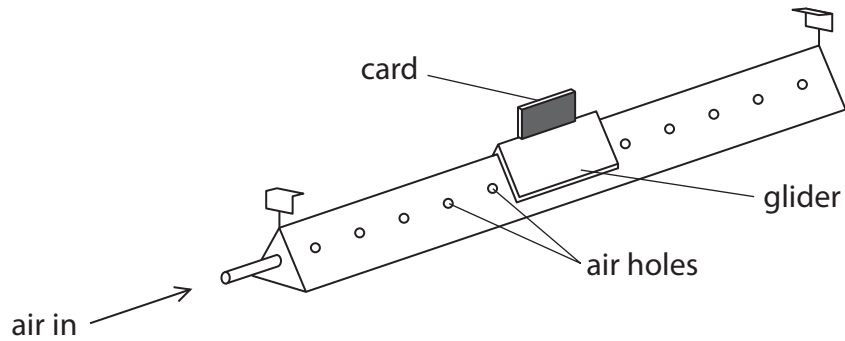

(a) (i) The diagram below shows the glider at rest on the air track.

Complete the diagram to show the forces acting on the glider.

Label the forces.

One force arrow has been drawn for you.

(3)

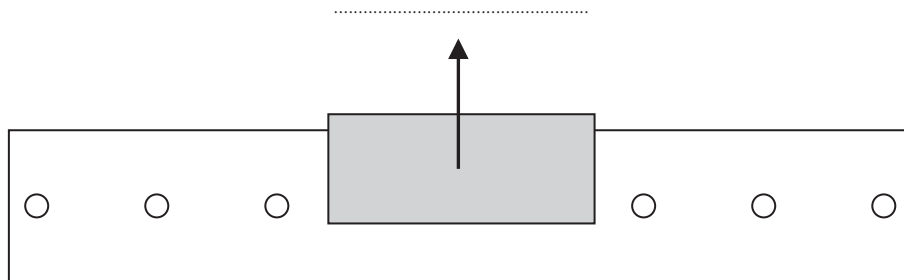

(ii) Explain what effect the cushion of air has on the movement of the glider.

(2)

.....

.....

.....

.....

- (b) Two light gates connected to a data logger are placed above the air track so that the card will pass through them.

The glider moves at a constant speed to the right.

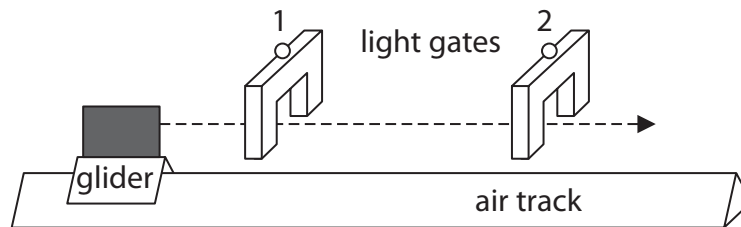

The length of the card is 8.3 cm.

The card takes 314 ms to pass through the first light gate.

- (i) State the relationship between average speed, distance moved and time taken.

(1)

- (ii) Calculate the average speed of the card as it passes through the first light gate.

(2)

average speed = cm/s

- (iii) State the time taken for the card to pass through the second light gate.

(1)

time taken =ms

(Total for Question 3 = 9 marks)

4 A student investigates the extension of an elastic band for different forces.

(a) (i) List the laboratory apparatus that the student needs for this investigation.

(3)

.....

.....

.....

.....

.....

.....

(ii) Extension, force and temperature are variables for this investigation.

Draw a line from each variable to its type.

(2)

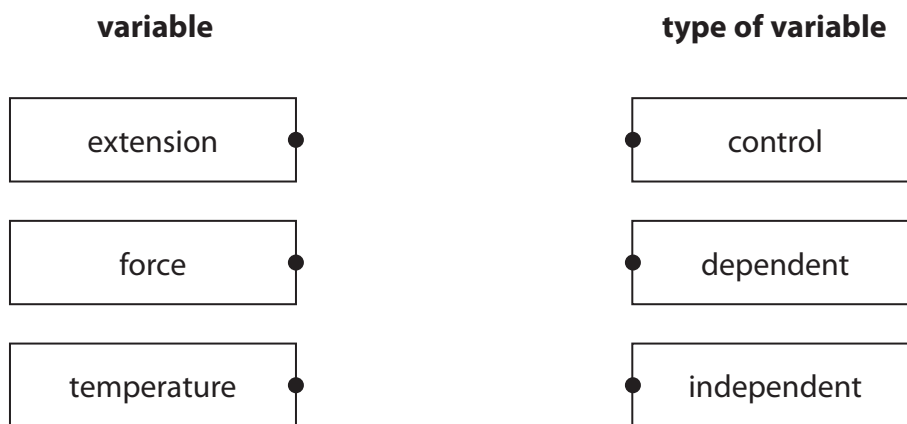

(iii) Describe how the student can measure the extension of the elastic band when he adds a force of 12 N.

(2)

.....

.....

.....

.....

(b) The student obtains this data as he first adds weights to the elastic band (loading) and as he then removes weights from the band (unloading).

Force in N	Extension in cm
	Loading
0	0.0
2	2.3
4	5.3
6	9.8
8	15.3
10	20.0

Force in N	Extension in cm
	Unloading
0	0.0
1	1.4
3	5.0
7	14.8
9	19.1
10	20.0

He plots the loading data on a graph as shown.

(i) Suggest how the student could improve the quality of his data. (2)

.....

.....

.....

.....

(ii) Draw a curve of best fit through the loading data. (1)

(iii) On the same axes, plot the unloading data. (2)

(iv) Draw a curve of best fit through the unloading data. (1)

(v) The student concludes that the band is an elastic material and that it obeys Hooke's law.
Discuss whether his conclusion is correct.
You should support your argument with data. (3)

.....

.....

.....

.....

.....

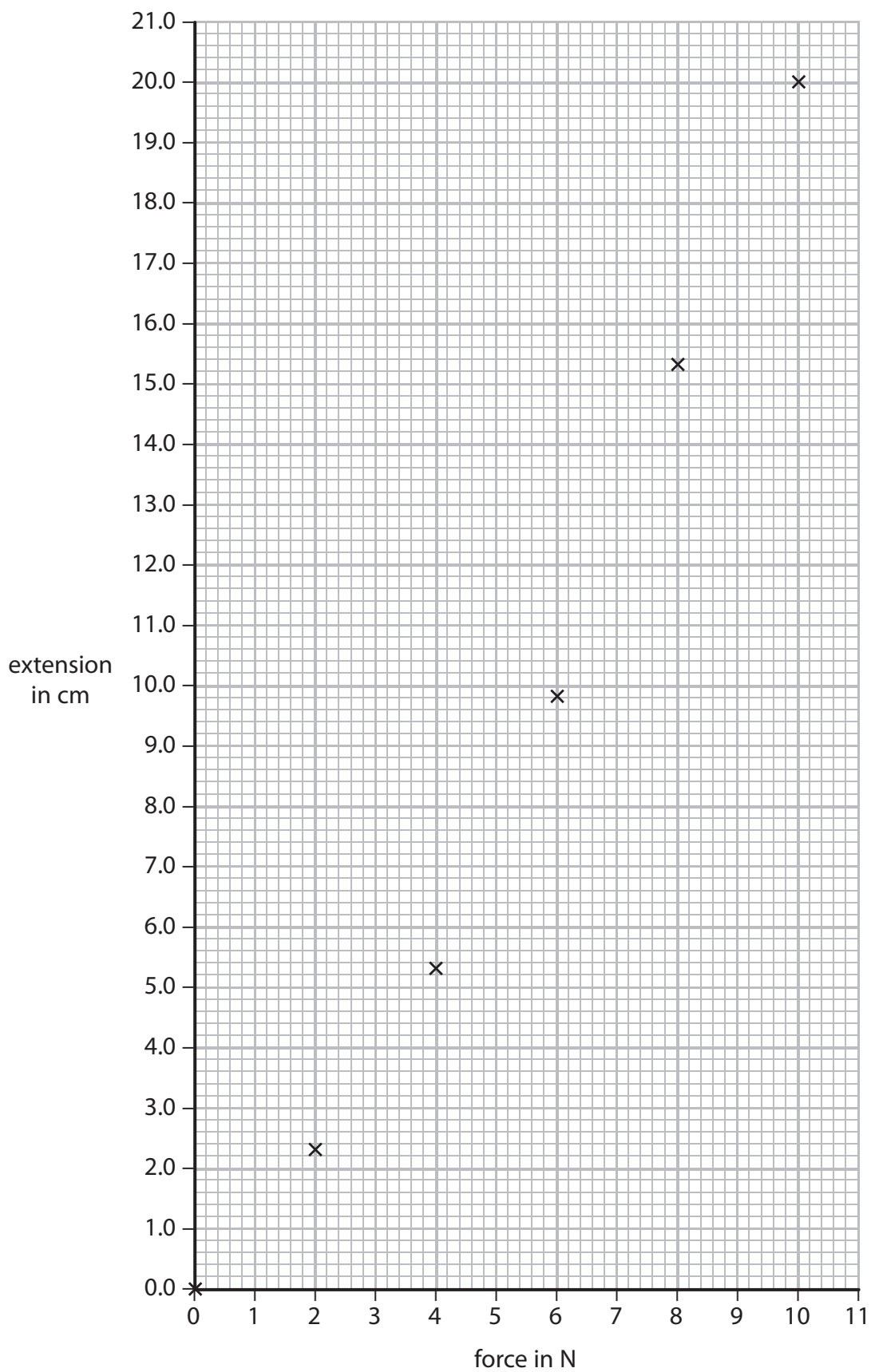

(Total for Question 4 = 16 marks)

5 The diagram shows a box attached to a parachute, falling at constant velocity.

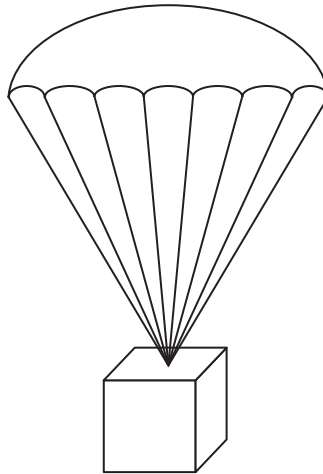

(a) State the name for this constant velocity.

(1)

.....

(b) Explain, in terms of forces, why the box and parachute fall at constant velocity.

(4)

.....
.....
.....
.....
.....
.....
.....
.....
.....
.....
.....
.....
.....
.....
.....
.....
.....
.....
.....
.....
.....
.....

(Total for Question 5 = 5 marks)

6 A student investigates the motion of a toy car as it moves freely down a slope.

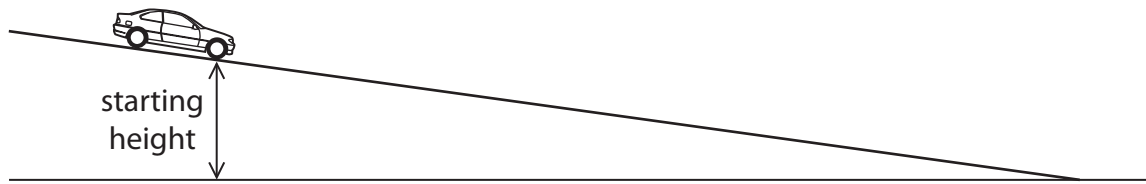

The student wants to find the link between the starting height of the car and the speed of the car at the bottom of the slope.

(a) (i) State the independent variable in this investigation. (1)

.....

(ii) Suggest a link between the starting height of the car and its speed at the bottom of the slope. (1)

.....

.....

(b) Describe how the student should measure the starting height of the car. (2)

.....

.....

.....

.....

(c) The student describes how she will find the speed of the car at the bottom of the slope.



I will start the timer when the car begins to move.
I will stop the timer when the car reaches the bottom.
I will find the speed at the bottom by dividing the distance moved by the time taken.

(i) Explain why the student will **not** be able to calculate the correct speed using this method.

(2)

.....

.....

.....

.....

(ii) Describe how the student should take the measurements needed to find the speed of the car at the bottom of the slope.

You should name any additional equipment needed.

(3)

.....

.....

.....

.....

.....

.....

.....

.....

.....

.....

(d) The student repeats the experiment using the same equipment and the same starting height.

She finds out that the time taken for the car to move down the slope is not exactly the same for each experiment.

Suggest three reasons why the student gets different results when she repeats the experiment.

(3)

1

.....

2

.....

3

.....

(Total for Question 6 = 12 marks)